



OWNER'S MANUAL

PureWatts 1000/1500

DC to AC POWER INVERTER



Introduction

Thank you for purchasing a Sinergex power inverter. The PureWatts power inverter series are members of the most advanced line of mobile AC power systems available.

The PureWatts 1000 and 1500 are used in a wide range of applications, including remote homes, recreational vehicles, boats, heavy trucking, and mobile utility vehicles. The PureWatts 1000 and 1500 will operate most televisions, video cassette recorders, power tools, personal computers, analog microwave ovens, drills, sanders grinders, mixers and blenders and many other types of equipment that require AC power.

To get maximum performance from you inverter, it must be installed correctly. Please take the time to read the instructions in this owner's manual before installing and operation.

1. Front Panel.

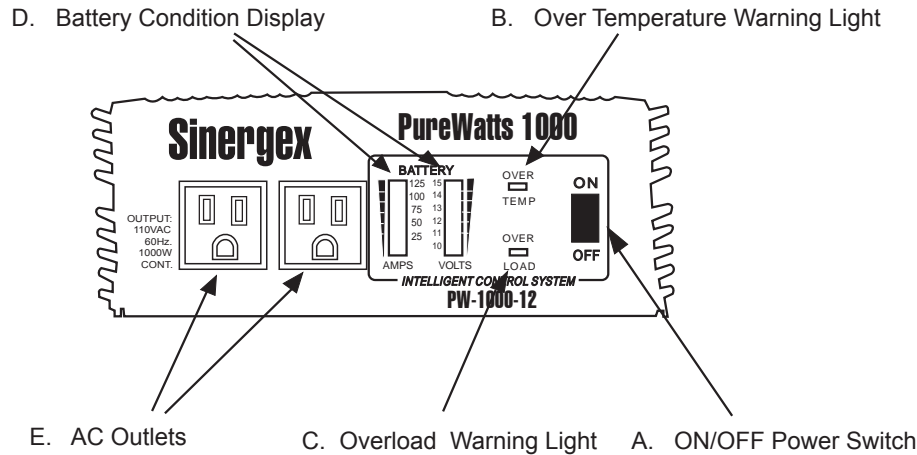

A. ON / OFF Power Switch:

Ensure the switch is in the OFF position during installation.

B. Over Heating Warning Light

The over heating warning light will turn on when the inverter protects itself against over-heating. The inverter will automatically shut down when the warning light is on. The will restart automatically and warning light will turn off when the inverter cools.

Once inverter has cooled continue normal operation.

C. Overload Warning Light.

The overload warning light will turn on and the inverter will shut down when overloading occurs. To reset the inverter, turn the power ON/OFF switch to the OFF position and decrease the power load. Once load is decreased turn the inverter power ON/OFF switch to the ON position and proceed normal operation.

D. Battery Condition Display.

The battery condition display gives information on the voltage and current of your battery. For optimum performance the current should be in the green zone of the display for continuous operation. The inverter will operate for several minutes in the yellow zone. Operation in the red zone of voltage or current will result in the inverter's protective shut down.

E. AC Outlets.

Outlet Sockets Available: North America
Europe (Schuko)
United Kingdom
Australia/New Zealand

2. Rear Panel

A. Ventilation Window

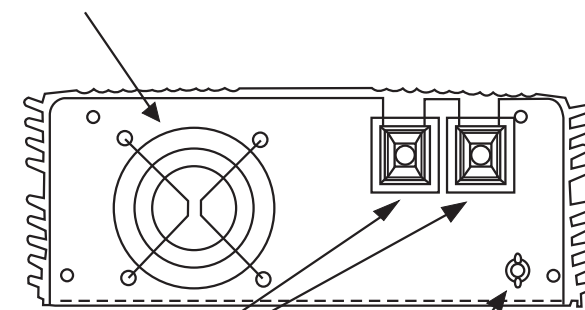

B. DC Battery Terminals

C. Chassis Grounding

A. Ventilation Window:

Do not obstruct. Must allow a minimum of 1 inch space for air flow.

B. DC Battery Terminals:

Connect the inverters to a 12 or 24 volt battery or another 12 or 24 volt power source. Red is positive (+) and Black is Negative (-). **WARNING:** Ensure that when connecting DC source to inverter, that the negative cable runs to negative terminal and the positive cable runs to positive terminal. Reversing these will blow an internal fuse and may cause permanent damage to the inverter. **REVERSE POLARITY WILL VOID WARRANTY!**

C. Chassis Grounding Lug:

Connect the chassis grounding lug to earth ground or to vehicle chassis using # 8 AWG wire.

WARNING: Operation of the inverter without proper ground connection may result in an electrical safety hazard.

QUICK INSTALLATION AND TESTING

If you would like to test the inverter and check its performance before final installation, please follow these guidelines:

1. Unpack and inspect the inverter. Ensure the power ON/OFF switch is in the OFF position.
2. Connect the DC cables to the DC battery terminals on the rear panel of the inverter. The red terminal is positive (+) and the black terminal is negative (-). Connect the cables into the correct terminals and tighten the terminal securely.
3. Connect the DC cables for the negative (-) terminal of the inverter to the negative (-) terminal of the battery. Ensure a secure connection is made.

CAUTION! The failure to make a secure connection between the battery and the inverter terminals will result in excessive voltage drop and may cause overheating of the cables and the insulation to melt.

4. Before proceeding with test, carefully check to ensure that the cables are connected to the correct terminals. That is negative (-) to negative (-) and positive (+) to positive (+).

CAUTION! Reverse polarity connection will blow an internal fuse and may cause permanent damage to the inverter. **DAMAGE CAUSED BY REVERSE POLARITY CONNECTION IS NOT COVERED UNDER WARRANTY.**

5. Connect the cable from the positive terminal of the inverter to the positive terminal of the battery. Ensure a secure connection is made.

WARNING! You may observe a spark when you make this connection due to current flow to the inverter to charge capacitors within the inverter. Do not make this connection in the presence of flammable fumes or liquids or an explosion or fire may result.

6. Set the Power ON/OFF Switch to the ON position. Check the Battery Condition Display. The voltage display should indicate 11 to 14 Volts for the PW-1000-12 and PW-1500-12 and 22 to 28 Volts for the PW-1000-24 and PW-1500-24, depending on the battery or other power source.
7. Set the inverter Power ON/OFF Switch to the OFF Position. The lights on the display may blink and an internal alarm may sound momentarily. This is normal. Plug the test load into the AC receptacle on the front panel of the inverter. Leave the Power ON/OFF Switch in the OFF position.
8. Set the Power ON/OFF Switch to the ON position and turn the test load on. The inverter should supply AC power to the test load. If you desire to measure the true output R.M.S. voltage of the inverter a FLUKE 87 BACKMAN 4410 or TRIPLETT 4200 must be used.

WARNING! THE TESTING PROCEDURE ABOVE IS FOR TEST PURPOSES ONLY AND NOT FOR PERMANENT INSTALLATION.

PERMANENT INSTALLATION

1. Where to Install:

The inverter must be installed in a location that meets the following requirements:

- A. A dry location. Do not allow water or other liquids to drip or splash on the inverter. Water damage will void warranty.
- B. A Cool location. Ambient air temperature should be between 0 degrees Celsius (32 degrees Fahrenheit) and 40 degrees Celsius (110 degrees Fahrenheit). The cooler the location, the better performance will be achieved.

C. Ventilated Location: Allow as least one (1) inch of clearance around the inverter to allow good air flow. Ensure the ventilation windows on the rear and bottom of inverter are not obstructed. Efficient air flow will help the inverter achieve optimum performance.

D. Safe Location: Do not install the inverter in the same compartment as the batteries or in any compartment where flammable liquids or fumes may be or may become present.

2. CABLES

DC to AC power inverters require high amperage and low voltage DC power to low voltage/high amperage voltage AC power. To get maximum performance, connect the inverter directly to the battery with the heaviest cable available.

To achieve greater efficiency, keep the length of the cable between the inverter and the battery to a minimum. Please refer to chart below cable size.

Max.Watts Out	Approx. Amps Req'd	Wire Gauge
100 Watts	10 Amps	#18
150 Watts	15 Amps	#14
200 Watts	20 Amps	#12
300 Watts	30 Amps	#10
400 Watts	40 Amps	#8
600 Watts	60 Amps	#6 or 2 x #10
800 Watts	80 Amps	#4 or 2 x #8
1000 Watts	100 Amps	#2 or 2 x #6

CAUTION! TO AVOID SHORTING AT THE BATTERY WHICH MAY RESULT IN SPARKING OR POTENTIAL FIRE HAZARD, IT IS RECOMMENDED A FUSE BE INSTALLED IN THE POSITIVE (+) CABLE CLOSE TO THE BATTERY. PLEASE SEE FUSE SIZE RECOMMENDATIONS BELOW:

PureWatts 1000 - 150 AMP FUSE
 PureWatts 1500 - 200 AMP FUSE

CAUTION! THE FAILURE TO USE A FUSE AS DESCRIBED ABOVE MAY VOID WARRANTY.

3. GROUNDING

On the rear panel of the inverter is a grounding lug labeled "Chassis Ground". This lug is to connect the chassis of the inverter to the ground. The ground terminals in the AC outlets on the front panel of the inverter are also connected to the ground lug.

The chassis grounding lug must be connected to a grounding point. This grounding point will vary depending on where the inverter is installed. In a vehicle, connect the the chassis ground to the chassis of the vehicle. In a boat, connect the chassis ground to the boat's grounding system. In a fixed location, connect the chassis ground to the earth.

The neutral or common conductor of the inverter AC output circuit is connected to the chassis ground. Therefore, when the chassis is connected to ground, the neutral conductor will also be grounded. This conforms to the national electrical code requirements that separately derived AC sources (such as inverters and generators) have their neutral tied to ground in the same way that the neutral conductor from the utility line is tied to the ground at the AC breaker panel.

CAUTION! The negative (-) DC input of the inverter is connected to the inverter's chassis. Do not install the inverter in a positive ground DC system. A positive ground DC system has the positive terminal of the battery connected to the chassis of the vehicle or to the grounding point.

WARNING! Do not operate the inverter without connecting it to ground. Failure to do so may result in electrical shock or other electrical hazard.

OPERATION

To operate the power inverter, put the Power ON/OFF Switch to the ON position. The inverter is now ready to deliver AC power to your desired loads. If you are operating several loads from the inverter, turn them on separately after the inverter has been turned on. This will ensure the inverter does not have to deliver starting currents for all loads at once.

1. Controls and Indicators

The Power ON/OFF Switch turns the control circuit in the inverter

on and off. Switching the Power ON/OFF Switch to the off position does not disconnect power from the inverter.

When the inverter is in the OFF position, the inverter draws no current from the battery. When the inverter is in the ON position but with no load, the inverter draws less than 400 Ma (12 Volt Models) or 300Ma (24 Volt Models) from the battery.

2. Battery Voltage Display

The Battery Voltage Display indicates the voltage at the DC input terminals of the inverter. At low input current this voltage is very close to the battery voltage. At high input current this voltage will be lower than the battery voltage. The drop in voltage is due to voltage drop across the cable and DC connection. Ideally, the voltage should remain in the green zone of the display. If the voltage drops to the red zone the inverter may shut down to protect the battery.

3. Battery Current Display

The Battery Current Display indicates the the current drawn from the battery by the inverter. It will not indicate current drawn by other loads also connected to the battery.

For long term operation, the current should be in the green zone. The inverter will operate for short periods of time when current is in the yellow zone. If the current is in the red zone, it will reduce its output voltage to protect itself.

4. Over Heating Warning Light

The Over Heating Warning Light indicates that the inverter has shut itself down because it has overheated. The inverter may overheat because it has been operating at power levels beyond its rating, or because it has been installed in a location which does not allow it to dissipate the heat adequately. The inverter will restart automatically once it has cooled.

5. Overload Warning Light

The Overload Warning Light indicates that the inverter has shut itself down because its output circuit has been short circuited or severely overloaded. If this occurs switch the Power ON/OFF Switch to the Off position, correct the fault causing the overload, and then switch the Power ON/OFF Switch to the ON position.

Operating Limits

1. Power Output

The PureWatts 1000 and 1500 will operate most AC loads within its power rating. When determining whether a microwave oven can be operated by the PureWatts 1000 or 1500, remember that the power rating commonly advertised for microwave ovens is the cooking power (the power delivered to the food being cooked) not the power actually consumed by the microwave oven. The microwave oven will consume 40% to 100% more than its advertised rating. To be safe check the power rating on the back of the microwave oven to determine its actual power draw. The PureWatts 1500 will operate most microwave ovens rated up to 1700 watts.

Some induction motors used in refrigerators, freezers, pumps, vacuum cleaners and other motor operated equipment, require a very high surge current to be started. The inverter may not be able to start some motors which have very high surge requirements above their continuous rating.

If the inverter is unable to start a motor, observe the Battery Voltage Display while trying to start the motor. If the Battery Voltage Display drops below 11 Volts while the inverter is attempting to start the motor, this may be the reason the inverter is unable to start the motor. Make sure that the DC connections are secure and the battery is fully charged. If the DC connection is secure and battery fully charged you may require a larger battery to operate the motor.

2. Input Voltage

The inverter will operate from input voltages ranging from 10 Volts to 15 Volts for the 12 Volt models and 20 Volts to 30 Volts for the 24 Volt models. If the input voltage drops below 10.7 Volts (12 Volt Models) or 21.5 Volts (24 Volt Models) an audible alarm will sound and the Battery Voltage Display will be in the red zone indicating low battery power. The inverter will shut down if the input voltage drops below 10 Volts (12 Volt Models) or 20 Volts (24 Volt Models). This protects the battery from being over discharged.

The inverter will also shut down if the input voltage exceeds 15 Volt (12 Volt Model) or 30 Volts (24 Volt Models). This protects the inverter against excessive input voltage. The Battery Voltage Display will be in the upper red zone when this occurs. Although the PureWatts 1000 and 1500 have built in protection against over voltage, damage may still occur if input voltage is allowed to exceed 20 Volts (12 Volt Models) or 30 Volts (24 Volt Models).

Troubleshooting

1. Common Problems

A. Audible Buzz in Audio Systems

Some inexpensive stereo equipment will emit a buzzing noise from their loudspeakers when operated from the inverter. This is caused by the inability of the stereo equipment to filter the modified sine wave AC power produced by the inverter. The only solution to this problem is to use stereo equipment that incorporates a higher quality power supply.

B. Television Interference

Operation of the inverter can interfere with television reception on some channels. If this problem occurs the following steps may help alleviate the problem.

- Make sure the ground lug on the rear panel of the inverter is securely connected to the ground system of your vehicle, boat, RV, truck or home.
- Do not operate other high power loads with the inverter while using the television.
- Make sure that the antenna feeding your television provides an adequate ("snow free") signal and a high quality cable is used to connect the antenna to the television.
- Move the television as far away from the inverter as possible.
- Keep the cables between the battery and the inverter as short as possible and twist the cables together, about 2 to 3 twist per foot. This will help minimize radiated interference from the cables.

2. Trouble Shooting Guide

Problem and Symptoms	Possible Cause	Solution
Low output voltage (110V: 95 - 105 VAC. 220V: 190 - 210 VAC.)	Using inadequate voltmeter.	<ul style="list-style-type: none"> Use true RMS Reading meter See page 5 of owner's manual.

Problem and Symptoms	Possible Cause	Solution
Low output voltage and current display in red zone.	<ul style="list-style-type: none"> Overload 	Reduce load
No output voltage and voltage in lower red zone.	<ul style="list-style-type: none"> Low input voltage 	<ul style="list-style-type: none"> Recharge battery, check DC connection and cables.
No output voltage, no voltage indication.	<ul style="list-style-type: none"> Inverter switched off, no power to the inverter. Internal fuse open. Reverse DC Polarity 	<ul style="list-style-type: none"> Turn inverter on, check the wiring to the inverter. Have qualified service technician check inverter. Have a qualified service technician check inverter.
No output voltage, voltage display in upper red zone.	<ul style="list-style-type: none"> High input voltage 	<ul style="list-style-type: none"> Make sure the inverter is connected to 12 or 24 Volt battery. Check regulation of charging system.
Low battery alarm on continuously, voltage indicator below 11 Volts (12 Volt Model) or 22 Volts (24 Volt Model.)	<ul style="list-style-type: none"> Poor DC wiring, poor battery condition. 	<ul style="list-style-type: none"> Use proper cables and make secure connections. Replace battery.

Problem or Symptom	<input type="checkbox"/>	Possible Cause	Solution
No output voltage, over temperature warning light on, load in excess of: 1500 W : 150A(12V) or 75A(24V) 1000 W : 75A(12V) or 37.5A(24V)	<input type="checkbox"/>	Thermal Shutdown <input type="checkbox"/>	Allow inverter to cool. Reduce load.
No output voltage, over temperature warning light on, load less than: 1500 W : 150A(12V) or 75A(24V) 1000 W : 75 A(12V) or 37.5A(24V)	<input type="checkbox"/>	Thermal Shutdown <input type="checkbox"/> <input type="checkbox"/> <input type="checkbox"/>	Improve ventilation. Make sure ventilation windows are not obstructed. Reduce ambient temp.
No output voltage, over load warning light on.	<input type="checkbox"/>	Short circuit or wiring error. <input type="checkbox"/>	Check AC wiring for short circuit or reverse polarity.

Maintenance

Very little maintenance is required to keep your inverter operating properly. You should clean the inverter's exterior periodically with a cloth to prevent the accumulation of dust and dirt. To ensure connections remain secure, periodically tighten the connection.

Warranty

We warrant this product against defects in materials and workmanship for a period of two years from the date of purchase. In the unfortunate event that an inverter does fail, please contact Sinergex Technologies L.L.C or your local authorized distributor for return authorization and details. The failed unit will be repaired or replaced, as deemed necessary by Sinergex Technologies or its authorized distributor. This warranty will be void if the inverter has suffered any obvious physical damage or alteration, either internal or external. The warranty does not cover damage caused by improper use or installation including the use of unsuitable power sources, attempting to operate excessive loads, or use in unsuitable climates.

This warranty is the only warranty and Sinergex Technologies L.L.C.. makes no other warranties express or implied, including warranties or merchantability and fitness for a particular purpose.

Repair or replacement are the sole remedies and Sinergex Technologies L.L.C.. shall not be liable for damages, whether direct, incidental, special or consequential whether caused by negligence or other fault.

For Further Warranty Information Please Contact:

Sinergex Technologies L.L.C.
Utah, USA
Email: info@sinergex.com
www.sinergex.com

Or your local Sinergex Authorized Distributor.



Sinergex PureWatts 1000 and PureWatts 1500 Power Inverters
Made in Taiwan to USA and European Quality Standards

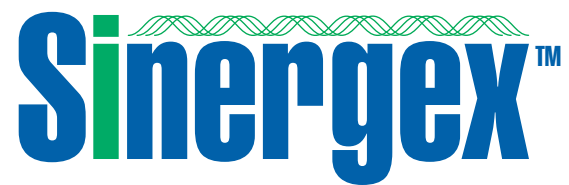

Sinergex Technologies L.L.C. (USA)
www.sinergex.com